

## ANTENNAS | HELI-12 SERIES

# UNI-DIRECTIONAL MINE & TUNNEL ANTENNA

## UNI-DIRECTIONAL 5000–6000 MHZ CIRCULAR POLARISED ANTENNA



- **Circular Polarised HELI antenna provides enhanced signal propagation and connection stability within a tunnel**
- **Left Hand Circular (LHC) & Right Hand Circular (RHC) Polarised options available**
- **Uni-directional – radiates in one direction in a tunnel**
- **Ruggedized & water ingress protected**
- **Ideal for Mining & Tunnel M2M and IoT deployments**



APPLICATION AREAS

### Product Overview

The HELI-12 forms part of a series of MiniHELI antennas. These antennas are only mini in size relative to their bigger brothers, the HELI-3, HELI-4 & HELI-8, but offer medium to high gain, which makes these antennas ideal for mining tunnels where IoT/M2M connectivity is deployed and can also be used for coverage into the stopes.

The HELI-12 is a 5GHz antenna, radiating in one direction (i.e. Uni-directional), which make it ideal for the coverage of the 5GHz in mining and other type of tunnels. These antennas are typically used for the deployment of IoT within the tunnel to provide telemetry and mine automation. These antennas are available in both Left Hand Circular (LHC) & Right Hand Circular (RHC) polarised antenna elements to provide optimal decorrelation within a MIMO deployment when using the BRKT-45, resulting in the best of the two worlds; decorrelation due to the polarisation difference and spatial diversity to enhance MIMO performance and RF reliability to service the most severe connectivity within a demanding mining tunnel. The Wi-Fi connection propagates around tunnel bends in a non-Line of Sight scenario and provides immunity to many Wi-Fi signal disrupting objects such as trains and drilling machinery which appear to obscure the tunnel.

### Features

- Single port 5GHz antenna
- This antenna is especially designed for mining and other types of tunnels where rapid extension of network is required
- Uni-directional – radiates in one direction in a tunnel
- Left & Right Hand Circular Polarised available (for MIMO)
- Intrinsically safe version available on request

### Application Areas

- Supplementing fibre /leaky feeder cable “Hotspots” to areas to enhance mobility or extend networks to inaccessible areas
- Underground telemetry and automation
- Creating of complete underground in tunnel wide data networks and internet/LTE connectivity
- Seamless connection to personnel using cellular phones and smart devices and tablets



2x HELI-12 antennas mounted on the BRKT-45 for MIMO application

### HELI-12



### Frequency Bands

The HELI-12 is a Wi-Fi/ ISM antenna that works from 5000-6000 MHz

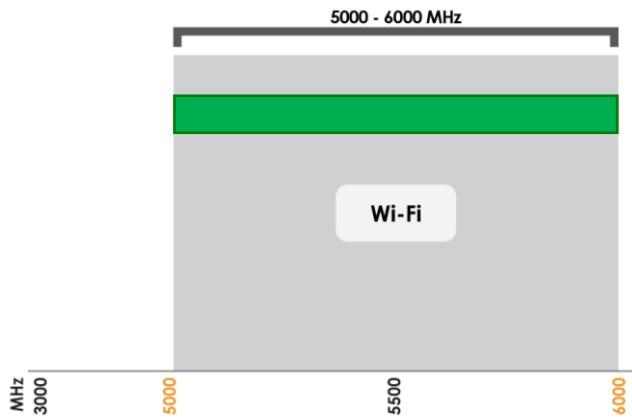

Indicates: 5GHz Wi-Fi / ISM Band

### Antenna Overview

Port	1
Frequency Bands	5000 MHz - 6000 MHz
Peak Gain	13.0 dBi
Coax Cable Type	RG-58
Coax Cable Length	350mm
Connector Type	N-Type Male

## Electrical Specifications

Frequency bands:	5000 MHz - 6000 MHz
Gain (max):	13.0 dBi
VSWR:	<1.5:1 over 90% of the band
Feed power handling:	30 W
Input impedance:	50 Ohm (nominal)
Polarisation:	Circular Polarised (LHC or RHC)
Coax cable loss:	2.10 dB /m @ 5.8 GHz
DC short:	N/A

## Coax Cable & Connector Type

Cable length:	350 mm
Coax cable type:	RG 58
Connector type:	N-Type (Male)

*\*The coax cable & connector is factory mounted to the antenna*

## Product Box Contents

Antenna:	A-HELI-0012-V2-01
----------	-------------------

## Ordering Information

Commercial name:	HELI-12
------------------	---------

### a) Right Hand Circular Version

Order product code:	A-HELI-0012-V2-01-R
EAN number:	6009710920176

### b) Left Hand Circular Version

Order product code:	A-HELI-0012-V2-01-L
EAN number:	6009710920169

**Note: For MIMO application, order both Right Hand Circular and Left Hand Circular antennas.**

## Mechanical Specifications

Product dimensions	321 mm x 142 mm x 114 mm
Packaged dimensions:	360mm x 165mm x 140mm
Weight:	0.85 kg
Packaged weight:	1.35 kg
Radome material:	ABS & PVC
Radome colour:	Grey
Mounting Type:	Ceiling mounted

## Environmental Specifications, Certification & Approvals

Wind Survival:	<120 km/h
Temperature Range (Operating):	-40°C to +70°C
Environmental Conditions:	Outdoor/Indoor
Water ingress protection ratio/standard:	IP 65
Salt Spray:	MIL-STD 810F/ASTM B117
Operating Relative Humidity:	Up to 98%
Storage Humidity:	5% to 95% - non-condensing
Storage Temperature:	-40°C to +70°C
Enclosure Flammability Rating:	UL 94-HB
Impact resistance:	IK 08
Product Safety & Environmental:	Complies with CE and RoHS standards



**Antenna Performance Plots**

**VSWR 5000-6000 MHz**

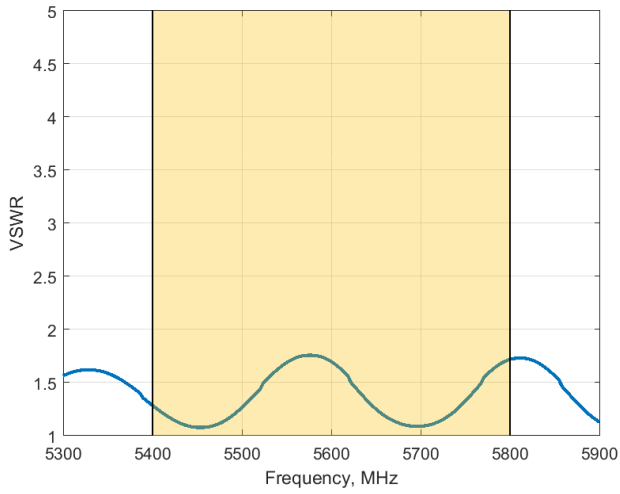

**GAIN 5000-6000 MHz (EXCLUDING CABLE LOSS)**

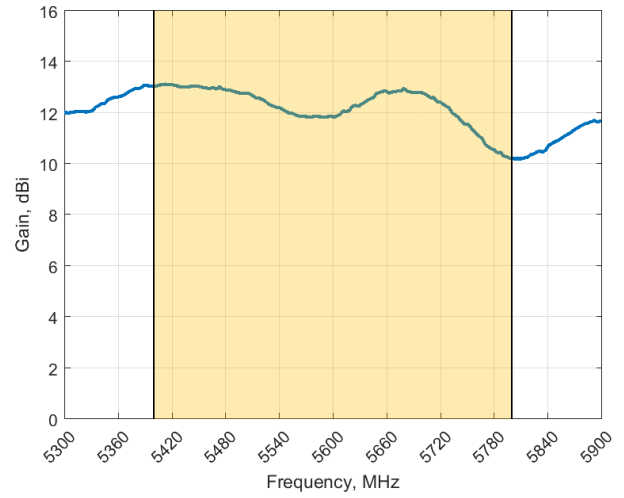

**Voltage Standing Wave Ratio (VSWR)**

VSWR is a measure of how efficiently radio-frequency power is transmitted from a power source, through a transmission line, into a load. In an ideal system, 100% of the energy is transmitted which corresponds to a VSWR of 1:1.

The HELI-12 delivers superior performance across all bands with a VSWR of 1.5:1 or better across 90% of the bands.

**Gain\* in dBi**

13.0 dBi is the peak gain from 5000 – 6000 MHz

*\*Antenna gain measured with circular polarised standard antenna*

Technical Drawings

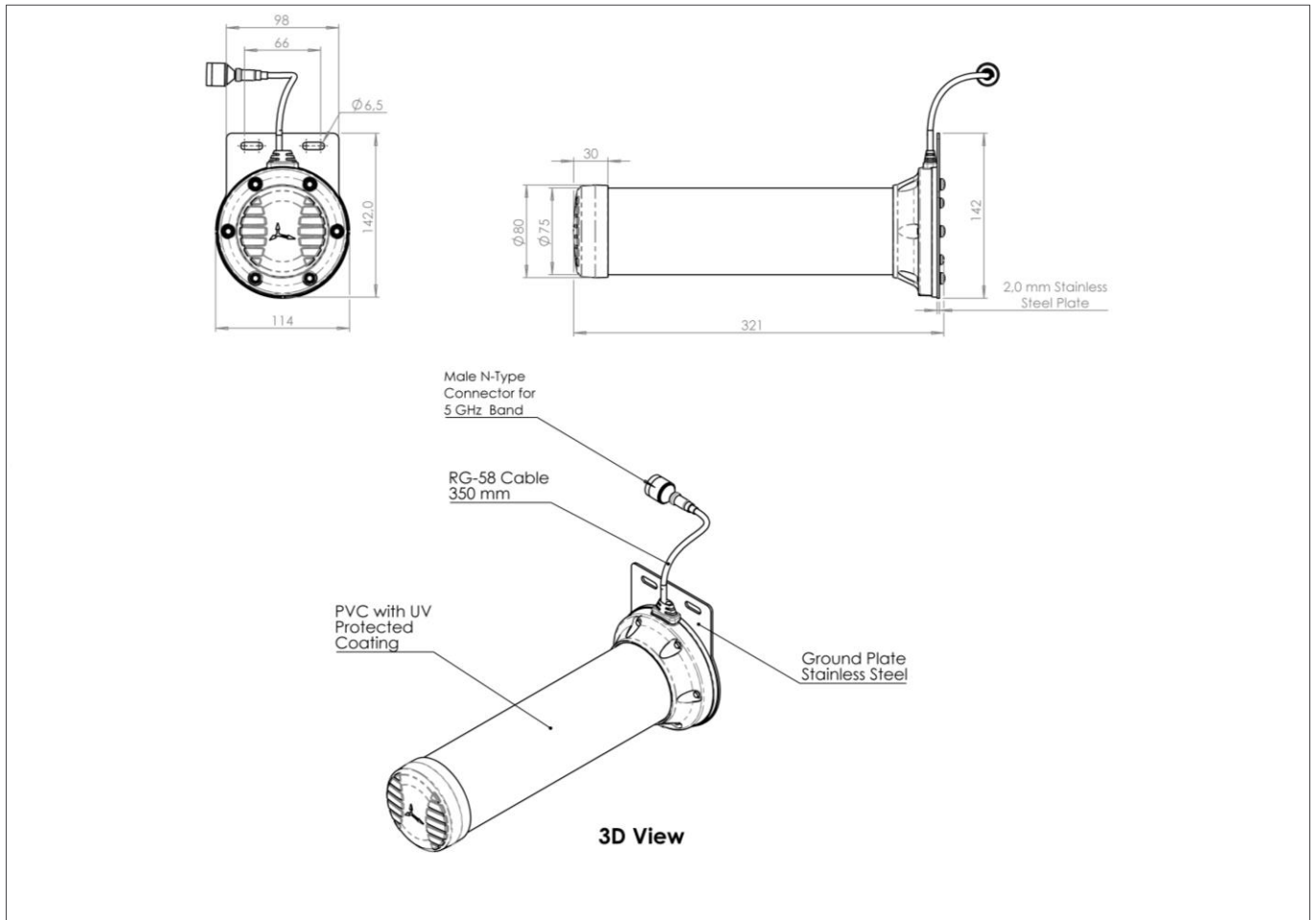

**Radiation Patterns**

Elevation: 5000-6000 MHz Azimuth: 5000-6000 MHz

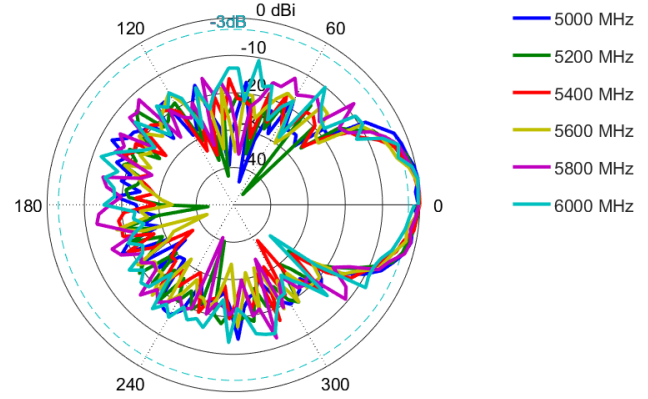
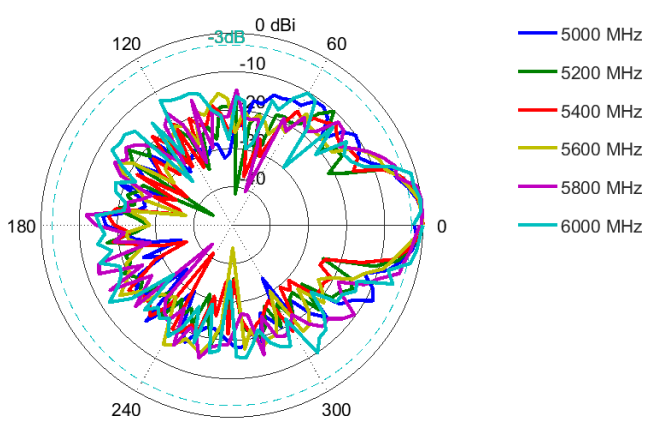

## Mounting Options



### Base Mount

The antenna can be fastened directly using the two slots on its base, via an L-bracket to a pipe or directly to another surface.



### Ceiling Mount (MIMO)- Optional

An optional Multi directional swivel bracket is available for mounting 2 x miniHELI antennas (right hand circular and left hand circular polarised antennas) to a ceiling for MIMO application

This option uses A-BRKT-045-V2-01.



### Roof Bolt Mounting - Optional

This optional 20mm roof bolt mounting bracket attachment is used in conjunction with BRKT-45 for mounting to standard mine roof bolts.

This option uses A-BRKT-047-V1-01.

---

**Additional Accessories****A – BRKT – 045 -V2 - 01**

Ceiling mounting bracket for holding mini-Heli Right hand and Left hand circular polarized antennas.

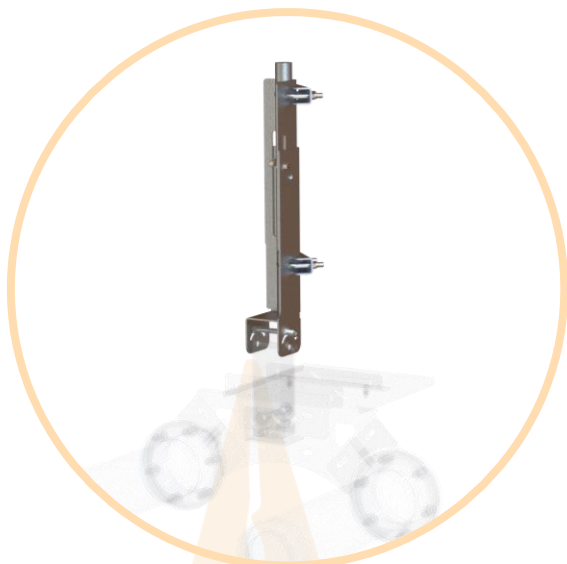
**A – BRKT – 047 -V1 - 01**

Ceiling 20mm Rod mounting bracket attachment to use with BRKT-45.

---

**Contact Poynting****Poynting Antennas (Pty) Ltd - Head Office**

Unit 4, N1 Industrial Park  
Landmarks Avenue,  
Samrand, 0157  
South Africa

**Phone:** +27 (0) 12 657 0050

**E-mail:** sales@poynting.co.za

**Poynting Europe**

Regus Business Center Neue Messe Riem  
Kronstadter Straße 4  
81677 München  
Germany

**Phone:** +49 89 208026538

**E-mail:** sales-europe@poynting.tech